

1 MEASURE SIZE OF MOUNTING TUBE TO DETERMINE CLAMP SCREW LENGTH

USE M6 x 30mm CLAMP SCREW
 IN HARDWARE KIT

OR

USE M6 x 50mm CLAMP SCREW
 IN HARDWARE KIT

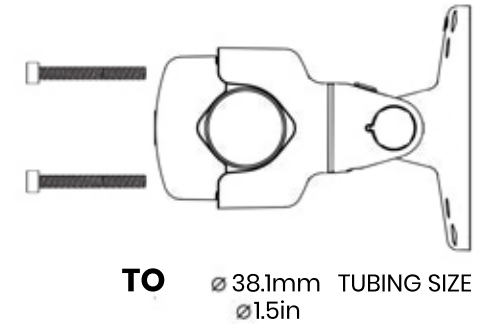
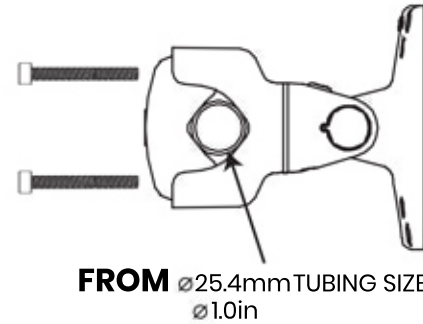
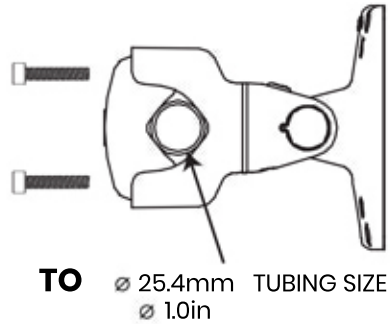
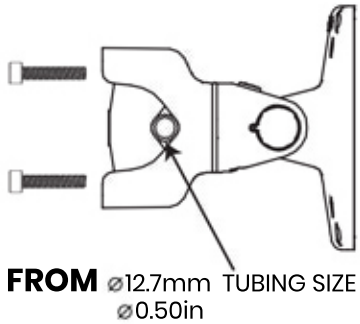

2 INSTALLATION ON MOUNTING TUBE

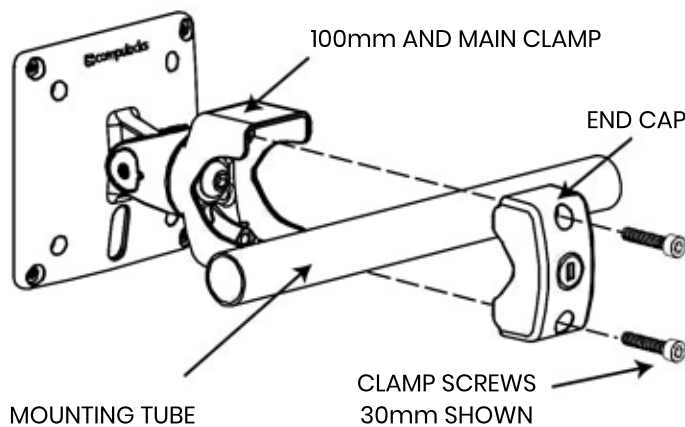

TIGHTEN CLAMP SCREWS EVENLY
 USING 5mm HEX WRENCH PROVIDED

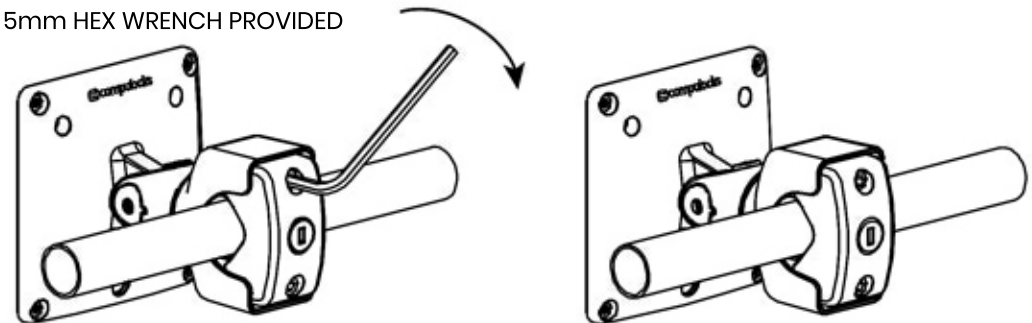

3 INSTALL TABLET ENCLOSURE (not included)

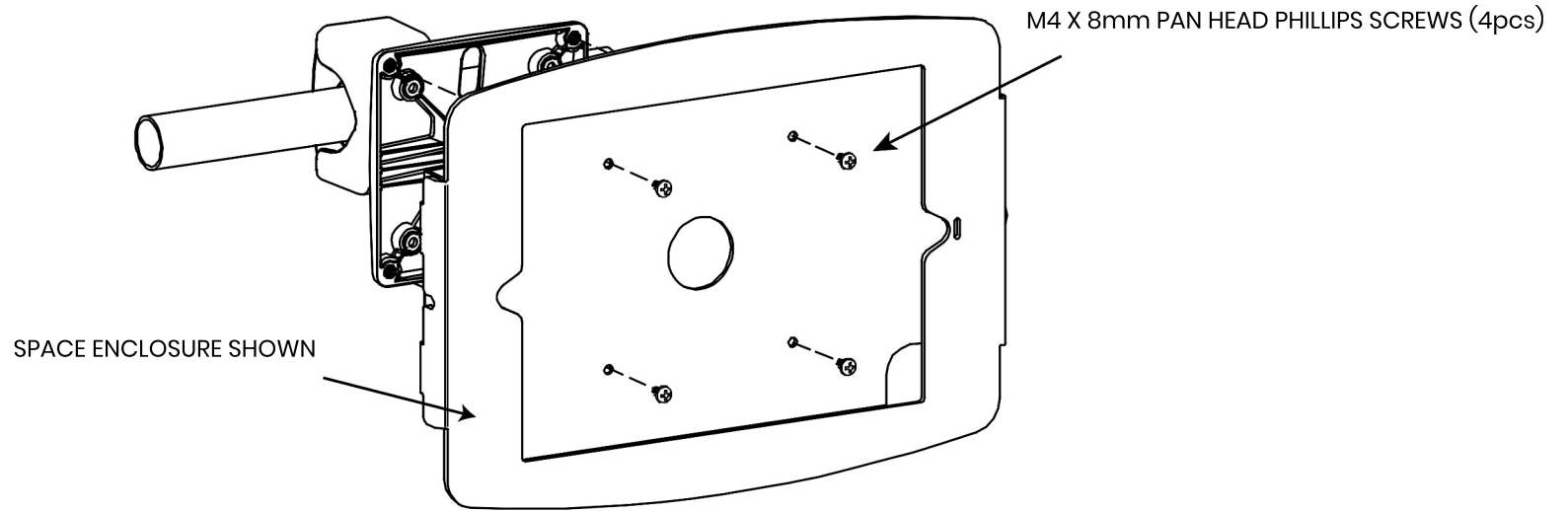

ADJUST TILT/TENSION

